

Maximizing EV-integration in LV-grids using the Universal Smart Energy Framework

Dr. E.J. Coster, H.A. Fidder, M. Broekmans

Stedin

Asset Management department

Rotterdam, The Netherlands

edward.coster@stedin.net

Abstract— It is to be expected that the number of electric vehicles will be growing in the near future. This can lead to serious grid congestion in low voltage grids and massive investments in solving this congestion. In this paper the integration of charging poles in LV-grids is studied with the aid of a Universal Smart Energy Framework. With this framework grid congestion can be solved via flexibility of loads and generation. The framework is applied in a pilot project in a neighbourhood of the city of Utrecht. This paper gives an overview of the framework, a description and goal of the pilot project as well as some preliminary results of implementing USEF in a real LV-grid.

Keywords-Electric Vehicles, charging poles, LV-grids, USEF, transactive energy systems, PV

I. INTRODUCTION

The traditional energy sector is changing. In the past electrical energy was generated in bulk by large centralized power plants while the trend is now to generate electricity with small distributed generation units, for instance Photo Voltaic (PV) systems. Besides a change at the generation side there is also a change at the demand side, for instance, an alternative ways for space heating by applying heat pumps. Another major development to be expected is the Electric Vehicle (EV) which will be replacing the fossil fueled cars in the future. These trends are ongoing and can have a significant impact on especially electricity distribution grids. As a DNO Stedin has to be prepared for the upcoming energy transition and adapt their grid design policies in such a way that this transition can be managed cost effectively and with a minimum of nuisance for their customers.

In the (recent) past most electric energy was consumed during evening time when people arrive at home. Common design figures were able to predict the electricity consumption quite well and with the aid of these figures and some design rules Low Voltage (LV) distribution grids could be designed in a ‘Fit and Forget’ fashion. This means that in for a certain neighborhood the peak load was estimated and the LV grid was dimensioned with some extra capacity

sufficient to operate the grid for at least 40 to 50 years. Integrating new types of systems, such as heat pumps, electric vehicles, battery storage systems and PV systems, lead to a different usage of the electricity grid with less predictable energy flows. There are many examples of LV grids who have an excessive integration of PV systems which lead to an export of electric energy towards the Medium Voltage (MV) grid in the afternoon exceeding the energy consumption in the evening. The new usage of LV grids have not been foreseen in the initial design of these grids and can lead to serious bottlenecks and large investments solving these bottlenecks.

Traditionally, grid reinforcements are the solution for bottlenecks however, new solutions are under development using flexibility in both energy demand and supply. Examples of solutions using customers flexibility are given in [4] where Demand Response (DR) is used to affect customers energy consumption applying price incentives as well as deployment of storage systems (batteries and hot water tanks) to cope with local fluctuation due to significant PV activity.

Stedin participated in the development of the Universal Smart Energy Framework (USEF) which can be considered as a transactive energy system. The goal of the USEF framework is solving grid congestion using the flexibility properties certain loads and energy source possess, such as shifting the charging of EV, storing PV power in local batteries, switching on (or off) heat pumps or ultimately curtailing PV generation (if other solutions will not work).

This energy framework is applied in a pilot project to manage the available grid capacity of local LV-grids. The pilot project involves the integration of twenty charging poles in existing LV grids in a neighborhood built in the mid-fifties. Also PV-systems are installed on rooftops. The goal of the pilot project is to charge the cars with PV generated energy as much as possible while managing the grid capacity via USEF.

In this paper in section II a general overview of the USEF framework will be given. This framework is applied in a test environment on an existing LV grid in a neighborhood where, amongst others, PV systems and charging poles are installed. Section III gives the details of the pilot project. The

main goals of the pilot project as well as some preliminary results will be discussed in section IV. The paper ends with conclusions which are presented in section V.

II. UNIVERSAL SMART ENERGY FRAMEWORK

As mentioned in the introduction the traditional solution to solve grid congestions is reinforcing the grid with extra cables. Because of the expected increase in bottlenecks in the LV-grid due to the energy transition this method is cost intensive and other solutions, based on unleashing flexibility, are under development. A solution which offers demand side flexibility is USEF.

Prosumers

Up to this moment the majority of household electric energy consumption occurs in a passive way. However, more and more consumers become active due to installation of PV and battery storage systems. These customers become prosumers which are customers who not only consuming electric energy but producing it as well. This prosumer becomes more flexible in his energy demand and supply [1].

Aggregator

The energy consumption of household appliances are such that the amount of flexibility which can be provided by the prosumers is not sufficient to contribute to load balancing or relief in grid congestion. Therefore aggregated flexibility is needed. This requires a role that is collecting the available flexibility of a group of prosumers and aggregates it to a larger volume of flexibility. This role is the aggregator role. Collecting prosumers' flexibility and making it available to other roles require clear processes, responsibilities and message descriptions [1]. That is what USEF is about.

Central position in USEF is taken by the aggregator. The aggregator is responsible for acquiring flexibility from prosumers, aggregating it in a portfolio, and offering this flexibility services to different markets and market players. For the aggregator four possible different market players are distinguished [2]:

1. The Prosumer
2. The Distribution System Operator (DSO)
3. The Balance Responsible Party (BRP)
4. The Transmission System Operator (TSO)

In this paper the focus is on the prosumer and the DSO. More information on other market players can be found in [2]. The general USEF value chain is given in figure 1 and it can be clearly seen that the aggregator has the central position in the framework [3].



Fig 1: General USEF value chain [3]

Flexibility for the prosumer

Before flexibility is offered to other parties, a prosumer can use his own flexibility for in-home optimization. Via tariff incentives prosumer behavior is affected already. However, this approach most likely leads to sub-optimization due to the rigid tariff structure where actual need for flexibility is not reflected [2].

In figure 2 the flexibility service for the prosumer is shown. The offered services are mentioned as well as the value for the prosumer.

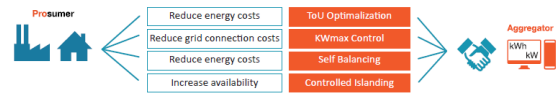

Fig 2: Flexibility service and value for the prosumer

Two important services are:

1. Time-of Use (ToU) optimization
2. kWmax control

Time-of-Use optimization can be considered as a load shift from high price intervals to low price intervals based on price signals. Benefit for the prosumer is lowering the energy bill. Control of the maximum load is based on reduction of the maximum load consumed by the prosumer. Some tariff structures are based on this maximum load value. Reducing this load can lead to a save of energy costs.

Aggregation services for the DSO

Via USEF the aggregator offers flexibility services to the DSO. These services are depicted in figure 3.



Fig 3: Aggregation services for the DSO

These flexibility services provide value by helping the DSO increase the performance and efficiency in managing the distribution grid.

In short the most important offered services are [2]:

- Congestion management

Avoiding of thermal overload by reducing peak loads

- Voltage problems

PV systems can increase the system voltage. By shifting load to a period of heavy export of PV generated power the voltage rise can be limited

- Grid capacity management

Load flexibility is used to optimize operational performance of assets to extend component lifetime, distributing loads evenly and so forth.

In this context these USEF services are applied in the Lombok Pilot project. USEF offers more services to more stakeholders and the details can be found in [2,3].

III. LOMBOK PILOT PROJECT

Recently with several partners Stedin has started a pilot project. In the pilot project the focus is on electric vehicle charging by solar power as much as possible. First part of the project consists of installing twenty charging poles in the Lombok neighbourhood of the city of Utrecht. These charging poles are used by residents who own an EV and voluntarily take part to the project. Besides the charging poles also PV systems are installed. These systems are mainly installed on public rooftops such as schools, for instance.

The final goal of the project is to create a neighbourhood energy system where EV is charged by PV-systems when there is a surplus of PV-power but also discharge the cars via Vehicle To Grid (V2G) charging poles when there is a power shortage. All installed charging poles in the pilot project have the capability for V2G.

Also a part of the project is *We Drive Solar* initiative. This initiative covers future need for mobility and consists of electric pool cars. These pool cars can be used by local residence which via a membership. The first 150 cars will be delivered in 2017 for the city of Utrecht and a part of these cars will be located in the neighbourhood of Lombok. A distinctive feature of this initiative is that these cars are also part of the neighbourhood energy system where the cars are used for local balancing of the power flow.



Fig 4: Electric Vehicle of the We Drive Solar Initiative

This means that generation peaks due to PV-systems are covered but also to solve grid congestion by offering flexibility during charging and V2G possibilities in times of a shortage of power. In figure 1 one of the first electric vehicles of the *We Drive Solar Initiative* is shown.

IV. USEF IMPLEMENTATION IN LOMBOK PILOT PROJECT

A. General USEF process

As discussed in the previous sections in this pilot project grid congestion will be solved via demand side flexibility as much as possible. In the USEF framework various roles are described however in this pilot project the most important roles are the aggregator role and the DSO role. In figure 3 a flowchart of the general USEF process is depicted. This flowchart shows the interaction between the aggregator, DSO and the USEF framework.

The process starts with a day-ahead load forecast provided by the aggregator. This is a prognosis based on 96 Program time Units (PTU, 15 min values) and covers the loads and generation which are represented by the aggregator. This forecast will be sent to USEF who will forward this message to the DSO.

After receiving the aggregators' load forecast the DSO completes the load data which is not represented by an aggregator and performs a grid safety analysis. In the grid safety analysis for all predefined congestion points the expected loading is determined for all 96 PTU values. In case of no grid congestion USEF will be informed by the DSO and USEF sends a message to the aggregator that no grid congestion will be expected hence the aggregator can proceed as scheduled.

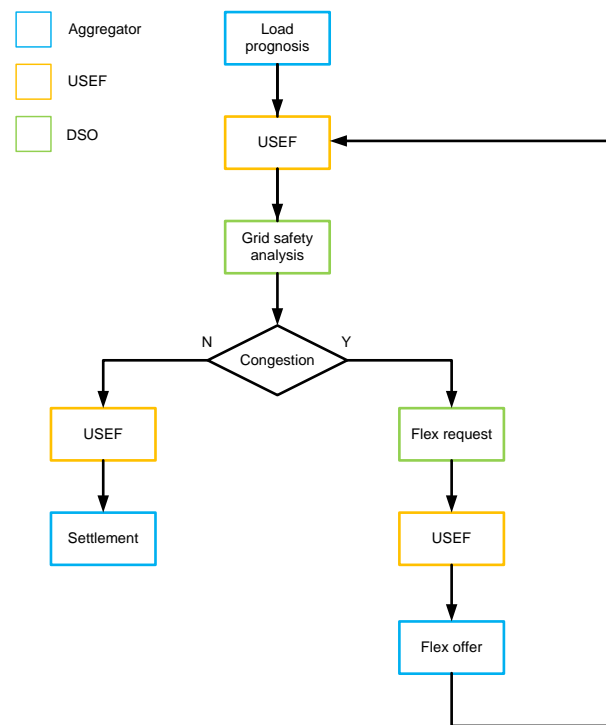

Fig 5 : Flow chart of general USEF process

Because per congestion point the available grid capacity is known, it can also be determined how much flexibility is needed to relieve the grid and solve the grid congestion. Therefore, in case of congestion a flex-request is sent out to USEF which is forwarded to the aggregator. The aggregator responds with a flex-offer and via USEF the grid safety analysis is repeated to check if the flex-offer is sufficient to solve the congestion. If this is the case a settlement procedure follows and the flex offer is ordered. In the future it is expected that multiple aggregators are active which can offer flexibility for certain grid congestion and then a market place is established where the best fitting flex-offer(s) will be ordered.

B. Implementation of the USEF framework

In the pilot project the charging poles are operated by the Charge Spot Operator (CPO) which has the ability to control the charging process of EV. However, the charging poles are managed by an aggregator. The aggregator has implemented

their part of the USEF framework in software to be able to provide the day-ahead forecast of all charging poles of the pilot project. Via the software the aggregator is also able to handle flex offers and orders.

For the grid safety analysis, the loads and generation not represented by the aggregator has to be estimated. This will be done in the Venios Energy Solution (VES) platform. In this platform a model of the involved LV-grids is implemented. The loads are forecasted based on predefined load profiles which are tuned via measurement data obtained from the LV-side of the distribution transformer and LV-feeder measurements. Details of the load forecast as well as the grid safety analysis will be given in the next section.

In figure 4 an overview of a part of a secondary substation, the low voltage switchgear, is shown. On the wall a cabinet is mounted in which the measurement devices are housed. The measurement devices measure all electric quantities (P, Q, I, V, p.f. kWh, kVArh) as well as Power Quality phenomena.

To check the proper execution of the flex orders all charging poles are individually measured. These measurements are also used for near real-time monitoring of the LV-grids. This near real-time monitoring is also performed in the VES platform.



Fig 6 : Low voltage switchgear and measurement cabinet

C. Characteristics of the LV-grid Floresstraat

The LV-grid in the Lombok area dates from the mid-fifties and is being fed via several secondary substations where the voltage is transformed from 10 kV to 400 V. In this pilot project the Floresstraat substation is the most interesting due to the amount of PV systems and the number of charging poles. The LV-grid has a radial topology and the majority of the connections consists of households but also some shops are connected. The total number of connections is 341 which results in a maximum transformer load of approximately 300 kVA. In table 1 an overview of the charging poles and PV-systems of this secondary substation is given.

Table 1: Overview of charging poles and PV –systems of the Floresstraat substation

| | |
|--------------------------|-------|
| PV-systems | 31 kW |
| Number of charging poles | 9 |

In figure 7 loading data of a 3 month period of an outgoing feeder of the Floresstraat substation is given. This figure is based on 15 minutes values and the data is represented as boxplots. It can be clearly seen that there is not much variation during night time. It can also be seen that the power flow during day time reverses due to PV activity. This leads to a significant variation of the load especially in the afternoon where the PV-systems are the most active. The dots in figure 7 indicates outliers in the data. These outliers are checked with the daily time series of the load data and it can be concluded that these outliers are caused by charging actions.

In figure 8 loading data of the MV/LV transformer is given for a 3 month period. The load in this area is dominated by household loads hence the measurements show an expected loading pattern. The largest loading variation occurs in the afternoon and is caused by the PV-systems. During night times the variation of the load is limited. Again the indicated outliers are caused by charging actions of electric vehicles however the smallest outliers are caused by the PV-systems. In comparison with figure 7 the number of outliers has reduced due to stochastic cancelation of loads.

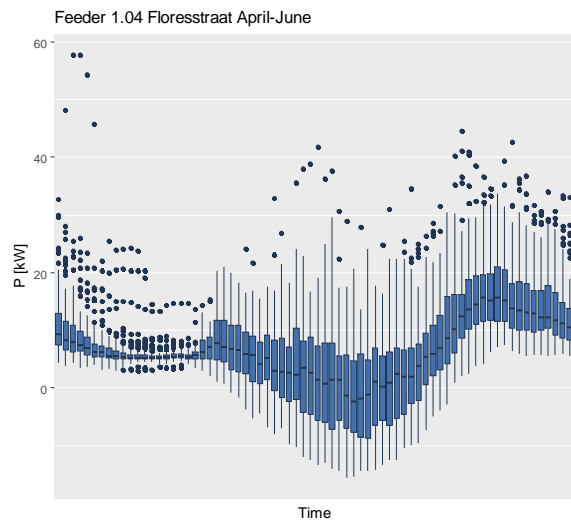

Fig 7: Boxplot of three month loading data of feeder 1.04

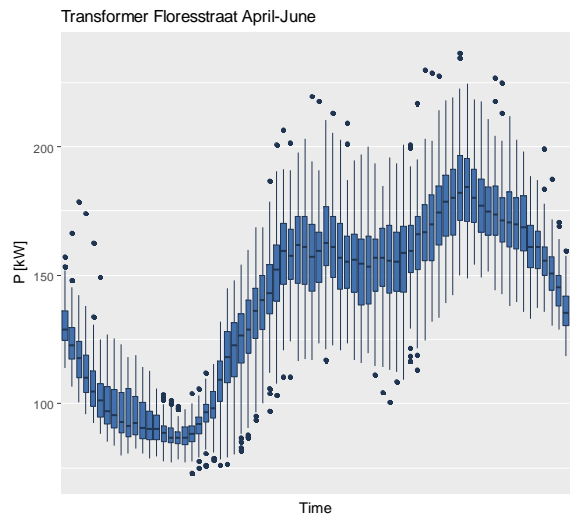

Fig 8: Boxplot of three month loading data of MV/LV transformer

V. GRID SAFETY ANALYSIS (GSA)

The intervention in the grid operation in order to control the load flow and to maintain the predetermined power quality requires the knowledge of the state of the electrical network. The best information on the power supply is obtained by installing measurement technology at all nodes in the network. Since this is not useful for economic reasons and it was not necessary in the past, only a few real-time measurements are available on the distribution network. Therefore, state estimation methods, which are necessary based on measured values in a few locations and a network model which determine the most probable state in the entire network, are necessary. At the level of the transmission networks, state estimation has been state of the art since the 1970s.

Distribution networks, however, differ, among other things. In their topology, the R / X ratio, the often unbalanced load and the high number of network nodes, differs strongly from the transmission networks. Furthermore, the state estimation methods in the transmission network serve to validate the measured values in a fully or over-determined system, while state estimation methods in the distribution network serve the replacement of measured values in a subordinate system. Processes for assessing the state of transmission networks cannot be transferred directly to the distribution network. In addition, many monitoring and control systems of the distribution network operators are not very high-tech. Procedures that already exist today usually can not specify a unique network state. You can only limit the solution space for the state of the network [4-5].

Hybrid approaches form a corresponding alternative. In this case, the grid is initially imaged and simulated as complete as possible with its feeders and consumers. The core of the simulation is formed by dynamic load and feed-in models, which partly access external data sources, as well as the concrete network topology. The state estimation is enriched by a limited amount of real measurement values which deliver a backward correction of the model results. The electrical network is divided into individual hierarchical measurement areas as a function of the topology. Measurement areas are generated whenever one or more measuring sensors delimit one or more network strings from the rest of the network [6]. The correction is made on the basis of the model results, in contrast to older approaches which carry out a linear or worst-case distribution [7].

The grid safety analysis (GSA) combines a pure simulation and the results of the state estimation. The dynamic load and feed-in models are continuously tuned by real measurements and by the results of the state estimation. Currently the tuning is integrated as an observed process. The simulation results are analyzed with regard to the transformer capacity, size of the fuses and the line parameters. A depth search approach also checks the load properties in dependence of the load direction. Necessary load reductions are then calculated per congestion point. The analysis also included the calculation of free capacities if the grid is within the defined safety range.

VI. DEMONSTRATION OF THE USEF PROCESS

In this section the USEF process is demonstrated step-by-step for a given congestion point in the pilot project. The figures presented in this section are used for testing purposes. The first step is determining the available grid capacity based on the regular connected load. An overview of this available grid capacity is shown in figure 9 where the USEF dashboard in the Venios application is given.

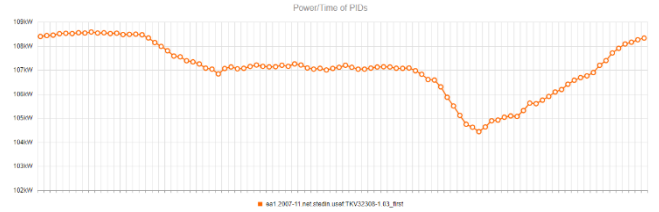

Fig 9: Available grid capacity for a congestion point in the pilot project

In figure 9 the graph starts at 2:00 AM and for 96 PTU's the available grid capacity is determined. It can be seen that during the evening the load at the congestion point is slightly higher resulting in a smaller available grid capacity.

Accordinging figure 5 the next step is sending the first D-prognosis of the estimated load of the aggregator's portfolio for the given congestion point. In this pilot project the aggregators portfolio consists of charging poles. With the aid of the available grid capacity the impact of first D-prognosis is checked via the GSA. The initial D-prognosis is shown in figure 10 while the results of the GSA are shown in figure 11.

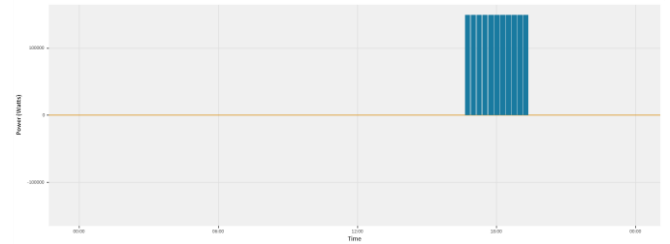

Fig 10: Initial D-prognosis

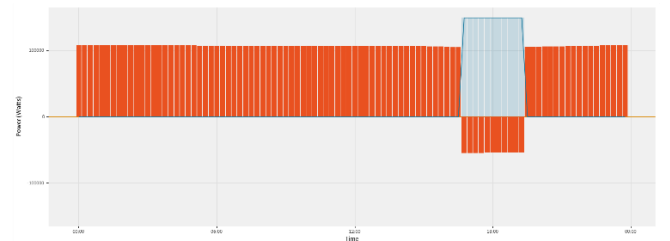

Fig 11: Results of the GSA for the initial D-prognosis

The results of the GSA shows that there is a shortage in grid capacity. This is indicated by the negative PTU-values in figure 11. According the flow chart of figure 5 there is grid congestion which leads to a flex request sent to the aggregator. The aggregator has to respond with a flex offer via a new D-prognosis where the aggregator try to solve the grid congestion. The flex offer of the aggregator (new D-

prognosis) is given in figure 12 (purple). For comparison reasons the first initial D-prognosis is also shown in blue.

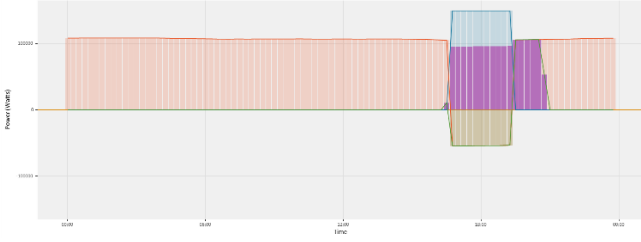
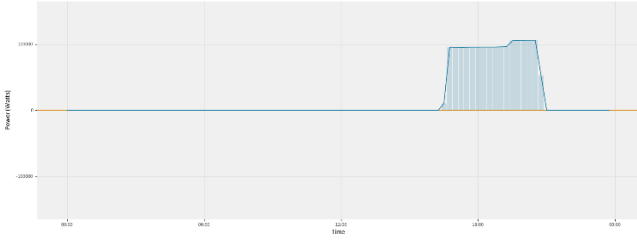

Fig 12: Initial D-prognosis and the second D-prognosis

As depicted in figure 12 the flex-offer does not exceed the available grid capacity. Furthermore, it can be seen that some of the load is shifted to a later period in time in such a way that the energy content of the first D-prognosis and the flex-offer (new D-prognosis) are the same.

For this flex-offer a new GSA has to be performed. The results of this GSA are given in figure 12.



ig 13: Results of the 2nd GSA

In figure 13 the flex requests are shown. The second d-prognosis is also shown and it can be seen that there are no further flex-requests present. When the correct flex-offers are received and the GSA shows that there is no grid congestion expected the next day all needed flexibility have to be ordered at the aggregator via a settlement procedure. During the day via the Venios dashboard the capacity use of the congestion point can be monitored.

VII. DISCUSSION AND OUTLOOK

A. Message exchange

During this pilot project some difficulties are encountered although the pilot project is still in the test phase. USEF is a framework which heavily relies on message exchange. Also, in the framework the format of these messages and the way they are exchanged are prescribed. This means that all involved parties have to implement these messages and the message exchange in a strict manner. In this pilot project a single aggregator is involved and it was already difficult to succeed in a successful message exchange even with a single aggregator.

The idea behind USEF is that multiple aggregators are acting on the defined congestion points. This means that all aggregators have to implement these message exchange in their system. Because aggregators apply different systems implementation of USEF can be a huge barrier and which also determines the success of USEF. The success of USEF

increases significantly when more and more parties adept USEF.

B. Nested Congestion points

USEF uses flexibility of the connected loads to manage the grid congestion. For feeders with a single congestion point this can be done by shifting, for instance, charging actions to an earlier or later time slot (PTU). However, in some cases there are also nested congestion points.

In figure 13 a transformer with multi-level congestion points are depicted. In this case multi-level means that congestion points are defined for outgoing feeders but also for the transformer where also the congestion points of the outgoing feeders are a part of. In general for the congestion points in figure 14 can be written:

$$P_{CP,n} = [P_{forecast,1} \dots P_{forecast,96}]^T \quad (1)$$

$$P_{cp\ transf.} = \sum_{n=1}^m P_{CP,n} \quad (2)$$

Equation (1) gives a vector of 96 PTU's for congestion point n . In (2) the transformer congestion is determined by summing all vectors of the m congestion points including the PTU vector of the remaining load.

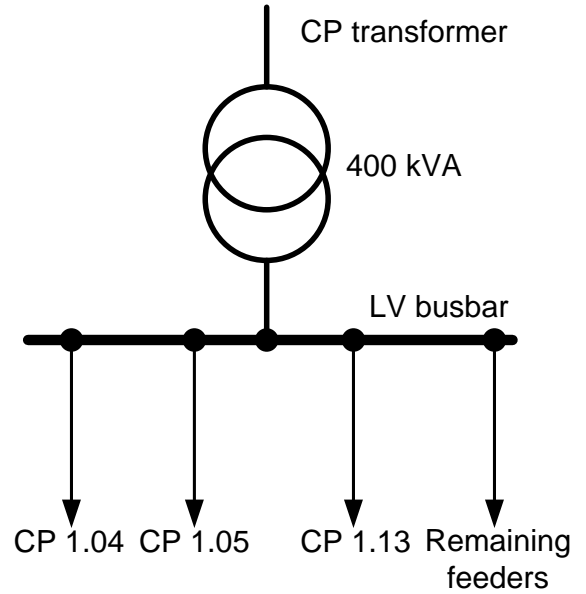

Fig 14: Secondary substation layout including congestion points

For figure 14 there are three congestion points defined hence $m=3$. For nested congestion points three types of congestion can occur:

1. Transformer congestion and no feeder congestion
2. Feeder congestion and no transformer congestion
3. Transformer and feeder congestion

For the first two types of congestion it is likely that a solution for the grid congestion will be found, however there might be a possibility that solving the feeder congestion results in transformer congestion. In case of both feeder and transformer congestion the problem of solving feeder congestion while creating transformer congestion and vice versa is more likely to happen. This can result in many flex-offers and GSA's to solve all congestion. During the first

tests this problem was recognized and a suitable solution is not found yet.

C. Forecast of charging poles

In this pilot project flexibility is offered by an aggregator. In this particular case the aggregator's portfolio consists of charging poles only hence the forecasts the aggregator has to make for the D-prognosis is a forecast of the utilization of the charging poles in a given PTU a day ahead. In some secondary substations the congestion points are defined on outgoing LV-feeders. To these feeders a limited number of charging poles are connected and it turned out that it is very difficult or even impossible to come up with an accurate estimation of the utilization of the charging poles. Forecasting becomes more accurate when the number of charging poles increase.

It is expected that in near future also PV-systems can be a part of the aggregator's portfolio. Due to the nature of PV-systems the output of a small group of PV-systems can be forecasted accurately already. Hence offered flexibility by curtailing PV-systems can be offered by the aggregator for congestion points defined at LV-feeders.

Because of the importance for an accurate forecast of sources of flexibility it is expected that systems like USEF performs better for congestion points defined at the MV/LV transformers and MV-feeders. If this is the case it is likely that grid congestion in LV-grids will be solved by traditional grid reinforcements while grid congestion in MV-grids will mainly be solved via sources of flexibility.

VIII. CONCLUSIONS

In this paper capacity management of low voltage networks using flexibility of EV charging is discussed. The flexibility is unleashed via the USEF framework which is applied in a pilot project in the Lombok neighbourhood of the city of Utrecht. A description of the pilot project as well as some preliminary results of key elements of the USEF process are given.

The current results are showing that the capacity management by USEF is working. Nevertheless, the long-time field operation will deliver additional results regarding the quality of the predictions and user experience due to the temporal capacity limitations.

As discussed in the paper the handling of nested congestion points can be difficult to solve. Attempts are made to come up with a multi-dimensional solution space by solving the preparation of flex-offer analytically but up till now no satisfactory results are found. Developments in this direction are ongoing.

With respect to the application of transactive systems like USEF it is experienced that for congestion points defined at outgoing LV-feeders accurate forecasting is difficult or even impossible. Therefore it is expected that these types of systems perform better and more accurately for congestion points defined at MV/LV transformers and MV-feeders. This can lead to the application of traditional grid reinforcements for local LV-grid congestion.

IX. REFERENCES

- [1] M. van den Berge, M. Broekmans, B. Derksen, A. Papanicolaou, C. Malavazos, 2016, "Flexibility provision in the Smart Grid era using USEF and OS4ES", in *proc. IEEE international Energy Conference (ENERGYCON)*
- [2] R. van Gerwen, H. de Heer, "USEF position paper: Flexibility Value Chain", www.usef.info, October 2015
- [3] M. van der Laan, "USEF position paper: Electric Mobility", www.usef.info, October 2015
- [4] B. Merkt, Beitrag zur Zustandsidentifikation von elektrischen Energieversorgungsnetzen. *Berichte aus der Elektrotechnik*. Shaker, 2008. ISBN : 9783832272289.
- [5] M. Wolter, Grid State Identification of Distribution Grids. *Berichte aus der Elektrotechnik*. Shaker, 2008. ISBN : 9783832275464.
- [6] C. Albrecht, Entwicklung einer skalierbaren Netzberechnungskomponente für ein Cloud-basiertes Monitoringsystem für Smart Grids, 2014, Ruhr Universität Bochum
- [7] N. Neusel-Lange. Dezentrale Zustandsüberwachung für intelligente Niederspannungsnetze: Neue Energie aus Wuppertal. Bd. 1. epubli GmbH, 2013.